

Bruciatori di gas ad aria soffiata

Blown gas burners

Brûleurs gaz à air soufflé

Gebläse-Gasbrenner

Quemadores de gas

Funzionamento bistadio progressivo o modulante
Progressive two-stage or modulating operation
Fonctionnement à 2 allures progressives ou modulant
Gleitend-zweistufiger oder modulierender Betrieb
Funcionamiento a dos llamas progresivas o modulante

COD.	MOD.	TYP.
3897302	RS 45/M <small>BLU</small>	827 T2
3897303	RS 45/M <small>BLU</small>	827 T2
3897340	RS 45/M <small>BLU</small>	827 T41
3897341	RS 45/M <small>BLU</small>	827 T41

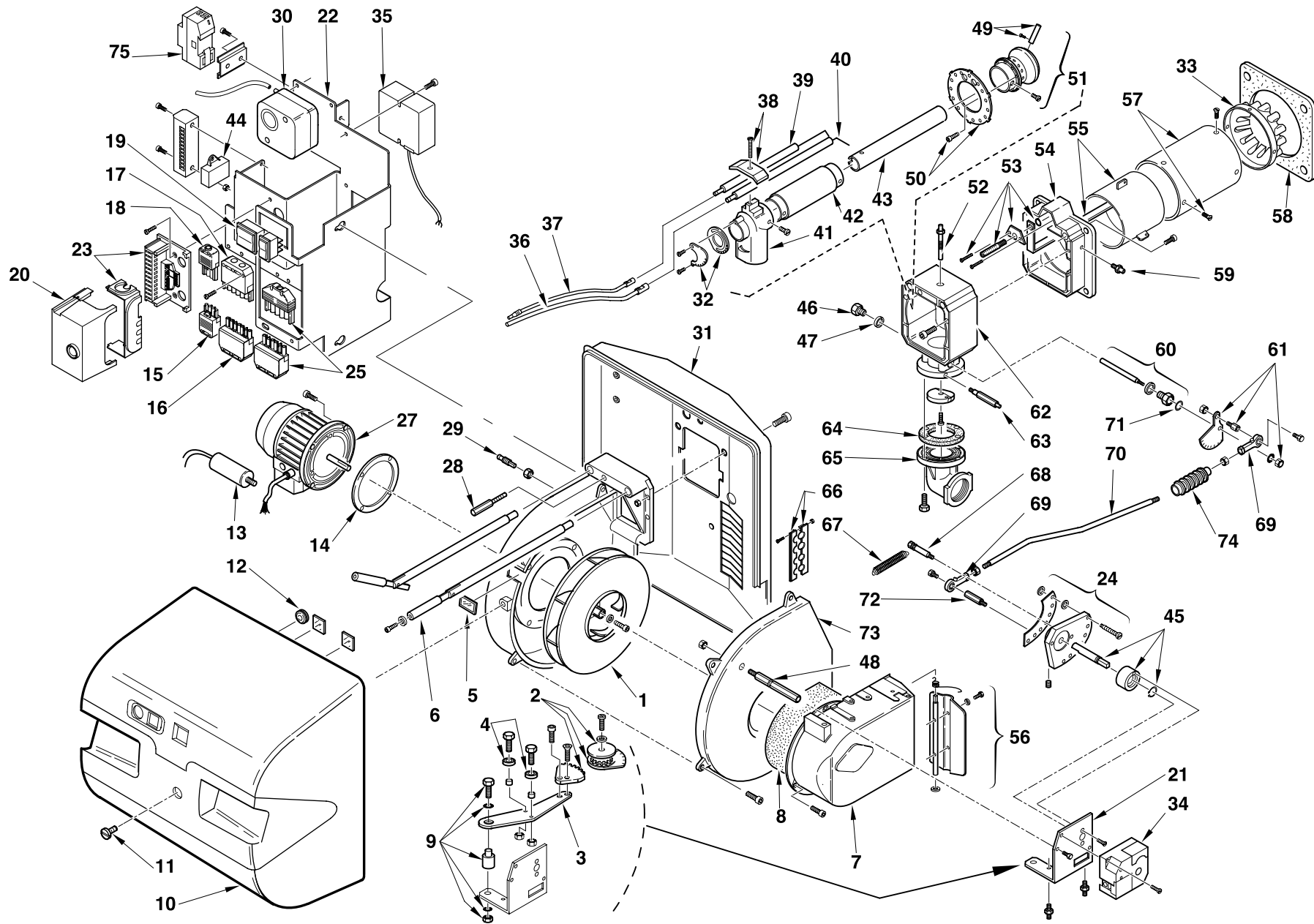

N.	COD.	3897302-827 T2	3897303-827 T2 *	3897340-827 T41	3897341-827 T41 *	DESCRIZIONE	DESCRIPTION	DESCRIPTION	BESCHREIBUNG	DENOMINACION	MATRICOLA BRUCIATORE	RICAMBI CONSIGLIATI	
											BURNER SERIAL NUMBER	ADVISED PARTS	
												MATRICULE BRULEUR	RECHANGE CONSEIL
												BRENNER KENN-NUMMER	EMPFOHLENE ERSATZTEILE
												MATRICULA QUEMADORES	RECAMBIOS ACONSEJADOS
													**
1	3003762	•	•	•	•	GIRANTE	FAN	TURBINE	GEBLÄSERAD	TURBINA		C	
2	3012063	•	•	•	•	QUADRANTE	GRADUATE SECTOR	SECTEUR GRADUE	SKALENSEGMENT	SECTOR GRADUADO			
3	3012064	•	•	•	•	LEVA	LEVER	LEVIER	HEBELSCHRAUBE	PALANCA			
4	3003841	•	•	•	•	CUSCINETTO	BEARING	ROULEMENT	LAGER	COJINETE			
5	3003763	•	•	•	•	VISORE	INSPECTION WINDOW	VISEUR	SICHTFENSTER	MIRILLA			
6	3003842	•	•	•	•	PERNO	BAR	GLISSIERE	BOLZEN	GUÍA		C	
7	3003890	•	•	•	•	BOCCA D'ASPIRAZIONE	AIR INTAKE	BOITIER D'ASPIRATION	ANSAUGÖFFNUNG	BOCA ASPIRACION			
8	3003830	•	•	•	•	FONOASSORBENTE	SOUND DAMPING	INSONORISANT	GERÄUSCHDÄMMUNG	AISLANTO ACUSTICO			
9	3003843	•	•	•	•	PERNO	SCREW	VIS CREUSE	HOHLKERNSCHRAUBE	GUÍA			
10	3003765	•	•	•	•	COFANO	COVER	COFFRET	VERKLEIDUNG	ENVOLENTE			
11	3003766	•	•	•	•	VITE	SCREW	VIS	SCHRAUBE	TORNILLO			
12	3007627	•	•	•	•	MEMBRANA	MEMBRAN	MEMBRANE	MEMBRANE	MEMBRANA			
13	3003767	•	•	•	•	CONDENSATORE	CONDENSER	CONDENSATEUR	KONDENSATOR	CONDENSADOR		B	
14	3012134	•	•	•	•	DISTANZIALE	SPACER	ENTRETOISE	DISTANZSTÜCK	DISTANCIADOR			
15	3006948	•	•	•	•	SPINA 4 POLI	4 POLE PLUG	FICHE 4 POLES	STECKER 4 POLEN	CONEC. HEMBRA DE 4 CONTAC.			
16	3006937	•	•	•	•	SPINA 7 POLI	7 POLE PLUG	FICHE 7 POLES	STECKER 7 POLEN	CONEC. HEMBRA DE 7 CONTAC.			
17	3006938	•	•	•	•	PRESA 7 POLI	7 POLE SOCKET	PRISE 7 POLES	STECKERBUCHSE 7 POLEN	CONEC. MACHO DE 7 CONTAC.			
18	3006949	•	•	•	•	PRESA 4 POLI	4 POLE SOCKET	PRISE 4 POLES	STECKERBUCHSE 4 POLEN	CONEC. MACHO DE 4 CONTAC.			
19	3012080	•	•	•	•	INTERRUTTORE	SWITCH	INTERRUPTEUR	SCHALTER	INTERRUPTOR		C	
20	3002478	•	•	•	•	APPARECCHIATURA	CONTROL BOX	BOITE DE CONTROLE	STEUERGERÄT	CAJA CONTROL		B	
21	3003886	•	•	•	•	SUPPORTO	SUPPORT	SUPPORT	HALTER	SOPORTE			
22	3012883	•	•	•	•	SUPPORTO	SUPPORT	SUPPORT	HALTER	SOPORTE			
23	3003596	•	•	•	•	ZOCCOLO	BASE	SOCLE	SOCKEL	ZOCALO		C	
24	3012062	•	•	•	•	CAMMA COMPLETA	CAM ASSEMBLY	CAME COMPLETE	VERBUNDREGLER	EXCÉNTRICO COMPLETO		C	
25	3013202	•	•	•	•	PRESA -SPINA 6 POLI	6 POLE SOCKET - PLUG	PRISE - FICHES 6 POLES	STECKERBUCHSE-STECKER 6 POLEN	CONEC. MACHO-HEMBRA DE 6 CONTAC.			
26													
27	3003771	•	•	•	•	MOTORE	MOTOR	MOTEUR	MOTOR	MOTOR		C	
28	3003778	•	•	•	•	ALBERINO	SHORT SHAFT	AXE	KLEINWELLE	ARBORILLO			
29	3003891	•	•	•	•	RACCORDO	CONNECTOR	MAMELON	NIPPEL	RACORD		C	
30	3007444	•	•	•	•	PRESSOSTATO ARIA	AIR PRESSURE SWITCH	PRESSOSTAT AIR	LUFTDRUCKWÄCHTER	PRESOSTATO DEL AIRE		A	
31	3003788	•	•	•	•	SCUDO ANTERIORE	FRONT SHIELD	BOUCLIER AVANT	VORDERES SCHILD	ESCUDO ANTERIOR			
32	3012326	•	•	•	•	GHIERA	FERRULE	DISQUE	STELLRING	CODO			
33	3012884	•	•	•	•	IMBUTO FIAMMA	END CONE	EMBOUT GUEULARD	FLAMMENROHR	TUBO EXTREMO		B	
34	3012885	•	•	•	•	SERVOMOTORE	SERVOMOTOR	SERVOMOTEUR	STELLMOTOR	SERVOMOTOR		B	
35	3002480	•	•	•	•	TRASFORMATORE	TRANSFORMER	TRANSFORMATEUR	ZÜNDTRANSFORMATOR	TRANSFORMADOR		B	
36	3003848	•	•	•	•	COLLEGAMENTO SONDA	PROBE LEADCONNECTION	POUR SONDE	VERBINDUNG FÜR SONDE	CABLE SONDA DE IONIZACIÓN		A	
37	3003794	•	•	•	•	COLLEGAMENTO ELETTRODO	H.T. LEAD	CONNECTION POUR ELECTRODE	VERBINDUNG FÜR ELEKTRODE	CABLE ELECTRODO		A	
38	3003409	•	•	•	•	CAVALLOTTO	U BOLT	CAVALIER	BÜGELBOLZEN	SOPORTE FIJACIÓN			
39	3012325	•	•	•	•	ELETTRODO	ELECTRODE	ELECTRODE PORCELAINE	ELEKTRODE	ELECTRODO		A	
39	3012886	•	•	•	•	ELETTRODO LUNGO	LONG ELECTRODE	ELECTRODE PORCELAINE LONG	LANGER ELEKTRODE	ELECTRODO		A	
40	3012173	•	•	•	•	SONDA	PROBE	SONDE	FÜHLER	SONDA		A	
40	3012176	•	•	•	•	SONDA LUNGA	LONG PROBE	SONDE LONG	LANGER FÜHLER	SONDA		A	
41	3012327	•	•	•	•	GOMITO	ELBOW	COUDE	SCHLITTEN	DISCO			
42	3012887	•	•	•	•	TUBO ESTERNO	EXTERIOR TUBE	TUYAU EXTERIEUR	AUSSERER ROHR	TUBO EXTERNO			

N.	COD.	3897302-827 T2	3897303-827 T2 *	3897340-827 T41	3897341-827 T41 *	DESCRIZIONE	DESCRIPTION	DESCRIPTION	BESCHREIBUNG	DENOMINACION	MATRICOLA BRUCIATORE BURNER SERIAL NUMBER MATRICULE BRULEUR BRENNER KENN-NUMMER MATRICULA QUEMADORES	RICAMBI CONSIGLIATI ADVISED PARTS RECHANGE CONSEIL EMPFOHLENE ERSATZTEILE RECAMBIOS ACONSEJADOS
												**
42	3012888	•	•	•	•	TUBO ESTERNO	EXTERIOR TUBE	TUYAU EXTERIEUR	AUSSERER ROHR	TUBO ESTERNO		
43	3012329	•	•	•	•	TUBO INTERNO	INTERIOR TUBE	TUYAU INTERIEUR	INNERER ROHR	TUBO INTERNO		
43	3012889	•	•	•	•	TUBO INTERNO	INTERIOR TUBE	TUYAU INTERIEUR	INNERER ROHR	TUBO INTERNO		
44	3012160	•	•	•	•	FILTRO ANTIDISTURBO	DEGLITCHER	FILTRE	ENTSTÖRER	FILTRO ANTI-INTERFERENCIA		C
45	3003885	•	•	•	•	ALBERO GAMMA	CAM-HOLDER SHAFT	PIVOT DE LA CAME	NOCKENWELLE	EJE DEL EXCENTRICO		
46	3003863	•	•	•	•	TAPPO	PLUG	BOUCHON A VIS	SCHRAUBSTÖPSEL	TAPÓN		
47	3007166	•	•	•	•	GUARNIZIONE	SEAL	RONDELLE	METALLDICHTUNG	JUNTA		B
48	3003889	•	•	•	•	COLONNETTA	STUD	COLONNETTE	SCHRAUBBOLZEN	COLUMNITA		
49	3013138	•	•	•	•	TUBETTO	TUBE	TUYAU	RÖHRCHEN	TUBO		
50	3012332	•	•	•	•	DISCO	DISC	DISQUE	SCHIEBE	TUBO LLAMA		A
51	3012891	•	•	•	•	DISTRIBUTORE GAS	HEAD	DISTRIBUTEUR	GASVERTEILER	DISTRIBUIDOR GAS		
52	3003873	•	•	•	•	GRUPPO MISURAZIONE	TEST POINT	PRISE DE PRESSION	MESSNIPPEL	GRUPO TOMA DE PRESION		
53	3003797	•	•	•	•	GRUPPO REGOLATORE	CONTROL DEVICE	GROUPE OBTURATION	DRUCKREGULIERUNG	GRUPO REGULADOR		
54	3012892	•	•	•	•	FRONTONE	FRONT PIECE	FACADE	VORDERTEIL	SOPORTE		
55	3012893	•	•	•	•	OTTURATORE	SHUTTER	OBTURATEUR	SCHIEBER	OBTURADOR		
55	3012894	•	•	•	•	OTTURATORE	SHUTTER	OBTURATEUR	SCHIEBER	OBTURADOR		
56	3012085	•	•	•	•	GRUPPO SERRANDA	AIR DAMPER ASSEMBLY	GROUPE VOLET AIR	LUFTKLAPPE	CONJUNTO REGISTRO DEL AIRE		
57	3012895	•	•	•	•	CILINDRO CORTO	SHORT SLEEVE	CYLINDRE COURT	KURZER ZYLINDER	CILINDRO		
57	3012896	•	•	•	•	CILINDRO LUNGO	LONG SLEEVE	CYLINDRE LONG	LANGER ZYLINDER	CILINDRO		
58	3003817	•	•	•	•	SCHERMO	FLANGE GASKET	ECRAN THERMIQUE	FLANSCHDICHTUNG	JUNTA AISLANTE		
59	3003893	•	•	•	•	GRUPPO MISURAZIONE	TEST POINT	PRISE DE PRESSION	MESSNIPPEL	GRUPO TOMA DE PRESION		
60	3003874	•	•	•	•	ALBERO MANICOTTO	BUTTERFLY VALVE SHAFT	AXE DE LA VANNE PAPILLON	SPINDEL GASDROSSEL	EJE VALVULA MARIPOSA		
61	3003875	•	•	•	•	QUADRANTE	GRADUATE SECTOR	SECTEUR GRADUE	SKALENSEGMENT	SECTOR GRADUADO		
62	3003876	•	•	•	•	MANICOTTO	MANIFOLD	MANCHON	GASANSCHLUSS	COLLARIN		
63	3003878	•	•	•	•	INDICE	INDEX	REPERE	INDEXSTIFT	INDICE		
64	3005483	•	•	•	•	GUARNIZIONE	SEAL	RONDELLE	METALLDICHTUNG	JUNTA		B
65	3006802	•	•	•	•	FLANGIA E GOMITO	FLANGE AND ELBOW	BRIDE ET COUDE	ANSCHLUSSFLANSCHGAS	BRIDA Y CODO		
66	3003780	•	•	•	•	PASSACAVO	FAIRLEAD	PASSE-CABLE	KABELDURCHGANG	PASACABLE		
67	3003879	•	•	•	•	MOLLA	SPRING	RESSORT	FEDER	MUELLE		A
68	3003880	•	•	•	•	PERNO	SCREW	VIS CREUSE	HOHLKERNSCHRAUBE	PERNO		C
69	3006098	•	•	•	•	SNODO SFERICO	PIN JOINT	CHAPE A ROTULE	KUGELGELENK	ARTICOLACION ESFERICA		C
70	3003881	•	•	•	•	TIRANTE	TIE ROD	TIRANT	GESTÄNGE	TIRANTE		
71	3003203	•	•	•	•	ANELLO	PISTON SEAL	JOINT TORIQUE	LIPPENDICHTUNG	ANILLO		
72	3003888	•	•	•	•	DISTANZIALE	SPACER	ENTRETOISE	DISTANZSTÜCK	DISTANCIADOR		
73	3003829	•	•	•	•	GUSCIO	HALF-SHELL	COUVERCLE	HAUBE	CASCARA		
74	3003883	•	•	•	•	CUFFIA	COWLING	PROTECTION	CAOUTCH.	SCHUTZCAPUZÓN		
75	3007269	•	•	•	•	INTERRUTTORE DIFF	GROUND FAULT INTERR.	INTERRUP DIFFEREN.	FEHLERSTROMSCHT.	INTERRUPTOR DIFERE.		

* = Versione Testa Lunga - Long Combustion Head Version - Version Tête Longue - Langer Brennkopf Ausführung - Versión alargado de tubo llama

**

A = Ricambi per dotazione minima - Spare parts for minimum fittings - Pièces détachées pour équipement minimum - Ersatzteile für minimale Ausstattung - Recambios para equipamiento mínimo

A+B = Ricambi per dotazione base di sicurezza - Spare parts for basic safety fittings - Pièces détachées pour équipement standard de sécurité - Ersatzteile für Sicherheitsgrundausrüstung - Recambios para equipamiento básico de seguridad

A+B+C = Ricambi per dotazione estesa di sicurezza - Spare parts for extended safety fittings - Pièces détachées pour équipement complet de sécurité - Ersatzteile für erweiterte Sicherheitsausrüstung - Recambios para equipamiento general de seguridad



RIELLO S.p.A.
Via degli Alpini 1
I - 37045 Legnago (VR)
Tel.: +39.0442.630111 Fax: +39.0442.22378
http:// www.rielloburners.com