

Bruciatori di gas ad aria soffiata

Blown gas burners

Brûleurs gaz à air soufflé

Gebläse-Gasbrenner

Funzionamento bistadio
Two stage operation
Fonctionnement à deux allures
Zweistufiger Betrieb

COD.	MOD.	TYP.
3788000	RS 160/M	843 T2
3788040	RS 160/M	843 T41

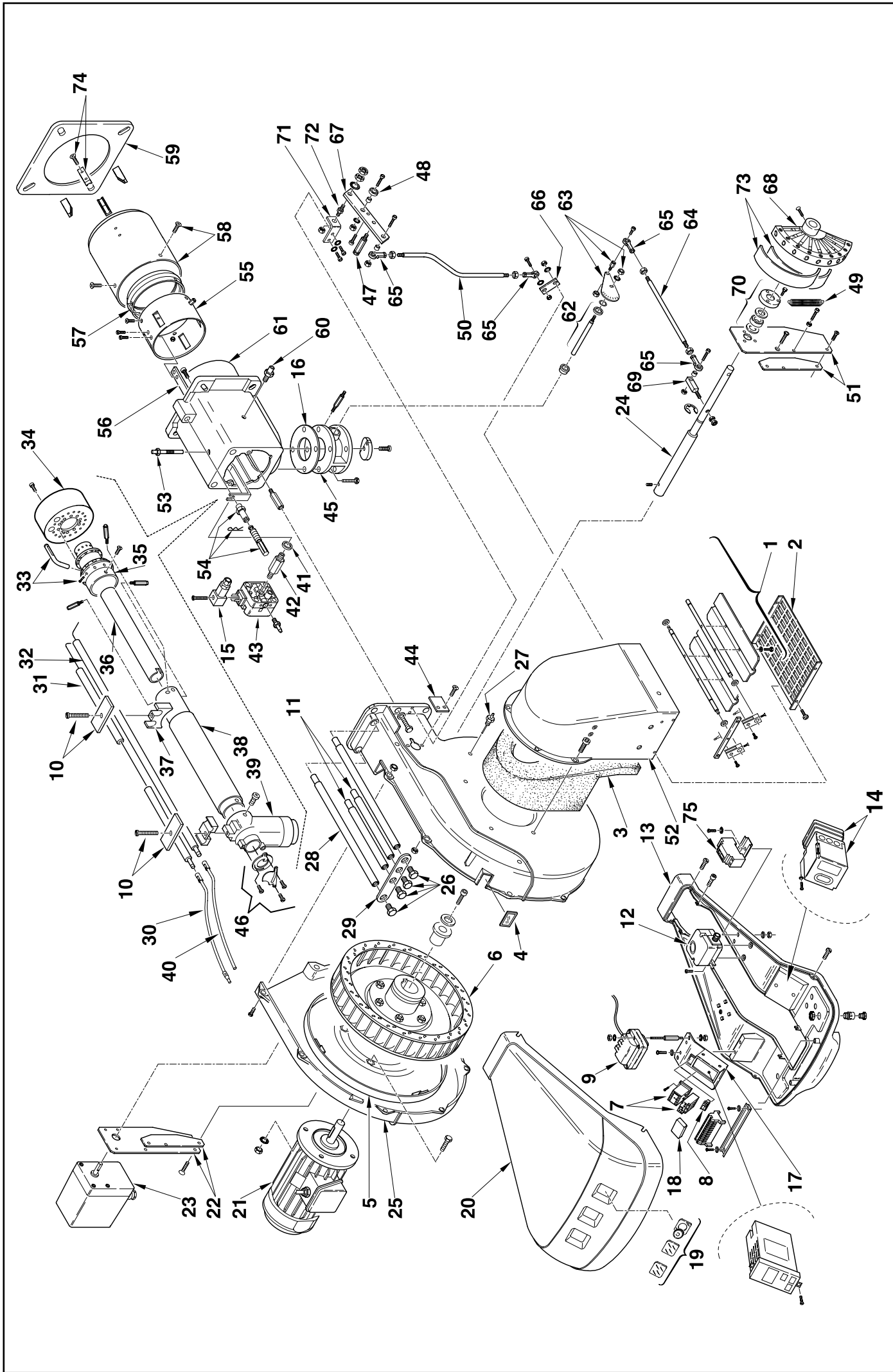

N.	COD.	DESCRIZIONE	DESCRIPTION		BESCHREIBUNG	MATRICOLA BRUCIATORE BURNER SERIAL NUMBER MATICULE BRULEUR BRENNER KENN-NUMMER
			DESCRIPTION	DESCRIPTION		
1	3012583	GRUPPO SERRANDA	AIR DAMPER ASSEMBLY	GRUPE VOLET AIR	LUFTKLAPPE	
2	3003086	PROTEZIONE	GRID	PROTECTION	SCHUTZGITTER	
3	3012553	FONOASSORBENTE	SOUND DAMPING	INSONORISANT	GERÄUSCHDÄMMUNG	
4	3003763	VISORE	INSPECTION WINDOW	VEISUR	SICHTFENSTER	
5	3012573	ANELLO	PISTON SEAL	JOINT TORIQUE	LIPPENDICHTUNG	
6	3012555	GIRANTE	FAN	TURBINE	GEBLÄSERAD	
7	3012584	RELE + CONTATTORE	OVERLOAD + CONTACTOR	RELAIS + CONTACTEUR	AUSLÖSER + SCHÜTZ	
8	3012080	INTERRUTTORE	SWITCH	INTERRUPTEUR	SCHALTER	
9	3003847	TRASFORMATORE	TRANSFORMER	TRANSFORMATEUR	ZÜNDTRANSFORMATOR	
10	3012626	PIASTRINA	PLATE	PLAQUETTE ETRIER	PLATTE	
11	3012627	PROLUNGA PERNO	BAR EXTENSION	RALLONGE DE GLISSIERE	VERLÄNGERUNG	
12	3007444	PRESSOSTATO ARIA	AIR PRESSURE SWITCH	PRESSOSTAT AIR	LUFTDRUCKWÄCHTER	
13	3012008	MENSOLA	BASE PLATE	PLAQUE DE SUPPORT	GRUNDPLATTE	
14	3006090	APPARECCHIATURA	CONTROL BOX	BOITE DE CONTROLE	STEUERGERÄT	
15	3012347	PRESA	SOCKET	PRISE	STECKBUCHSE	
16	3005482	GUARNIZIONE	SEAL	RONDELLE	FLANSCHDICHTUNG	
17	3012343	SUPPORTO	SUPPORT	SUPPORT	HALTER	
18	3012155	FILTRO ANTIDISTURBO	DEGLITCHER	FILTRE	ENTSTÖRER	
19	3003962	VETRINO	VIEWING PORT	REGARD	SCHAUGLAS	
20	3003963	COFANO	COVER	COFFRET	VERKLEIDUNG	
21	3012557	MOTORE	MOTOR	MOTEUR	MOTOR	
22	3012585	PIASTRA	ANCHOR PLATE	PLATINE DE BLOCAGE	ARRETIERPLATTE	
23	3012345	SERVOMOTORE	SERVOMOTOR	SERVOMOTEUR	STELLMOTOR	
24	3012349	ALBERO	SHAFT	ARBRE	WELLE	
25	3012587	GUSCIO	HALF-SHELL	COUVERCLE	HAUBE	
26	3003481	VITE	SCREW	VIS	SCHRAUBE	
27	3003891	RACCORDO	CONNECTOR	MAMELON	NIPPEL	
28	3012628	PERNO	BAR	GLISSIERE	BOLZEN	
29	3012629	STAFFA	BRACKET	SUPPORT	KONSOLE	
30	3003795	COLLEGAMENTO ELETTRODO	H.T. LEAD	CONNEXION POUR ELECTRODE	VERBINDUNG FÜR ELEKTRODE	
31	3012630	ELETTRODO	ELECTRODE	ELECTRODE PORCELAIN	ELEKTRODE	
32	3012178	SONDA	PROBE	SONDE	FÜHLER	
33	3012631	TUBETTO	TUBE	TUYAU	RÖHRCHEN	
34	3012632	TAZZA	AIR DIFFUSER	DIFFUSEUR D'AIR	FLAMMKOPFBECHE	
35	3012633	DISTRIBUTORE	GAS HEAD	DISTRIBUTEUR	GASVERTEILER	
36	3012634	TUBO INTERNO	INTERIOR TUBE	TUYAU INTERIEUR	INNERER ROHR	
37	3012635	SUPPORTO	SUPPORT	SUPPORT	HALTER	
38	3012636	TUBO ESTERNO	EXTERIOR TUBE	TUYAU EXTERIEUR	AUSSERER ROHR	
39	3012637	GOMITO	ELBOW	COUDE	SCHLITTEN	
40	3012043	COLLEGAMENTO SONDA	PROBE LEAD	CONNEXION POUR SONDE	VERBINDUNG FÜR SONDE	
41	3007088	GUARNIZIONE	SEAL	RONDELLE	METALLDICHTUNG	
42	3012674	RACCORDO	CONNECTOR	MAMELON	NIPPEL	
43	3003660	PRESSOSTATO GAS	GAS PRESSURE SWITCH	PRESSOSTAT GAZ	GAS DRUCKWÄCHTER	
44	3012638	PIASTRINA	PLATE	PLAQUETTE ETRIER	BEUGELPLATZE	
45	3006096	REGOLATORE GAS	GAS REGULATOR	REGULATEUR GAZ	GAS REGLER	

3788000-483 T2

3788040-483 T4

N. COD.	DESCRIZIONE	DESCRIPTION	DESCRIPTION	BESCHREIBUNG	MATRICOLA BRUCIATORE BURNER SERIAL NUMBER MATRICULE BRULEUR BRENNER KENN-NUMMER
46	3012014	GHIERA	FERRULE	DISQUE	STELLRING
47	3012352	PERNO	BAR	GLISSIERE	BOLZEN
48	3003841	CUSCINETTO	BEARING	ROULEMENT	LAGER
49	3012356	MOLLA	SPRING	RESSORT	FEDER
50	3012646	TIRANTE	TIE ROD	TIRANT	GESTANGE
51	3012594	PIASTRA	ANCHOR PLATE	PLATINE DE BLOCAGE	ARRETIERPLATTE
52	3012595	BOCCA D'ASPIRAZIONE	AIR INTAKE	BOITIER D'ASPIRATION	ANSAUGÖFFNUNG
53	3012049	VITE	SCREW	VIS	SCHRAUBE
54	3012639	GRUPPO REGOLATORE	CONTROL DEVICE	GRUPE OBTURATION	DRUCKREGULIERUNG
55	3012640	CILINDRO	SLEEVE	CYLINDRE	ZYLINDER
56	3012641	STAFFA	BRACKET	SUPPORT	KONSOLE
57	3012642	OTTURATORE	SHUTTER	OBTURATEUR	SCHIEBER
58	3012643	IMBUTO FIAMMA	END CONE	EMBOUT GUEULARD	FLAMMENROHR
59	3012562	SCHERMO	FLANGE GASKET	ECRAN THERMIQUE	FLASCHDICHTUNG
60	3003322	RACCORDO	CONNECTOR	MAMELON	NIPPEL
61	3012645	MANICOTTO	MANIFOLD	MANCHON	GASANSCHLUSS
62	3006132	ALBERO E ANELLO	SHAFT AND RING	ARBRE ET ANNEAU	WELLE UND RING
63	3012644	QUADRANTE	GRADUATE SECTOR	SECTEUR GRADUE	SKALENSEGMENT
64	3012600	TIRANTE	TIE ROD	TIRANT	GESTANGE
65	3006098	SNODO SFERICO	PIN JOINT	CHAPE A ROTULE	KUGELGELENK
66	3012601	LEVA	LEVER	LEVIER	HEBEL
67	3012354	LEVA	LEVER	LEVIER	HEBEL
68	3012358	CAMMA	CAM	CAME	NOCKEN
69	3012350	LEVA	LEVER	LEVIER	HEBEL
70	3012357	CUSCINETTO	BEARING	ROULEMENT	LAGER
71	3012602	SUPPORTO	SUPPORT	SUPPORT	HALTER
72	3012603	PERNO	BAR	GLISSIERE	BOLZEN
73	3006097	MOLLA	SPRING	RESSORT	FEDER
74	3012647	BASETTA	CENTERING SUPPORT	ELEMENT DE CENTRAGE	ZENTRIERHALTERUNG
75	3007269	INTERRUTTORE DIFFERENZIALE	GROUND FAULT INTERRUPTEUR	INTERRUPTEUR DIFFERENT.	FEHLERSTROMSCHUTZSCHALT



R.B.L. Bruciatori Legnago s.p.a.
I - 37045 Legnago (Verona) - Via degli Alpini, 1
Tel. + 442/630.111 - Fax + 442/21980