

Bruciatore di gasolio • Light oil burner • Brûleur fioul domestique • Öl-Gebläsebrenner
Quemador de gasóleo

Gulliver RG3D

COD. **3739454**

TIPO/TYP/TYP **394T1**

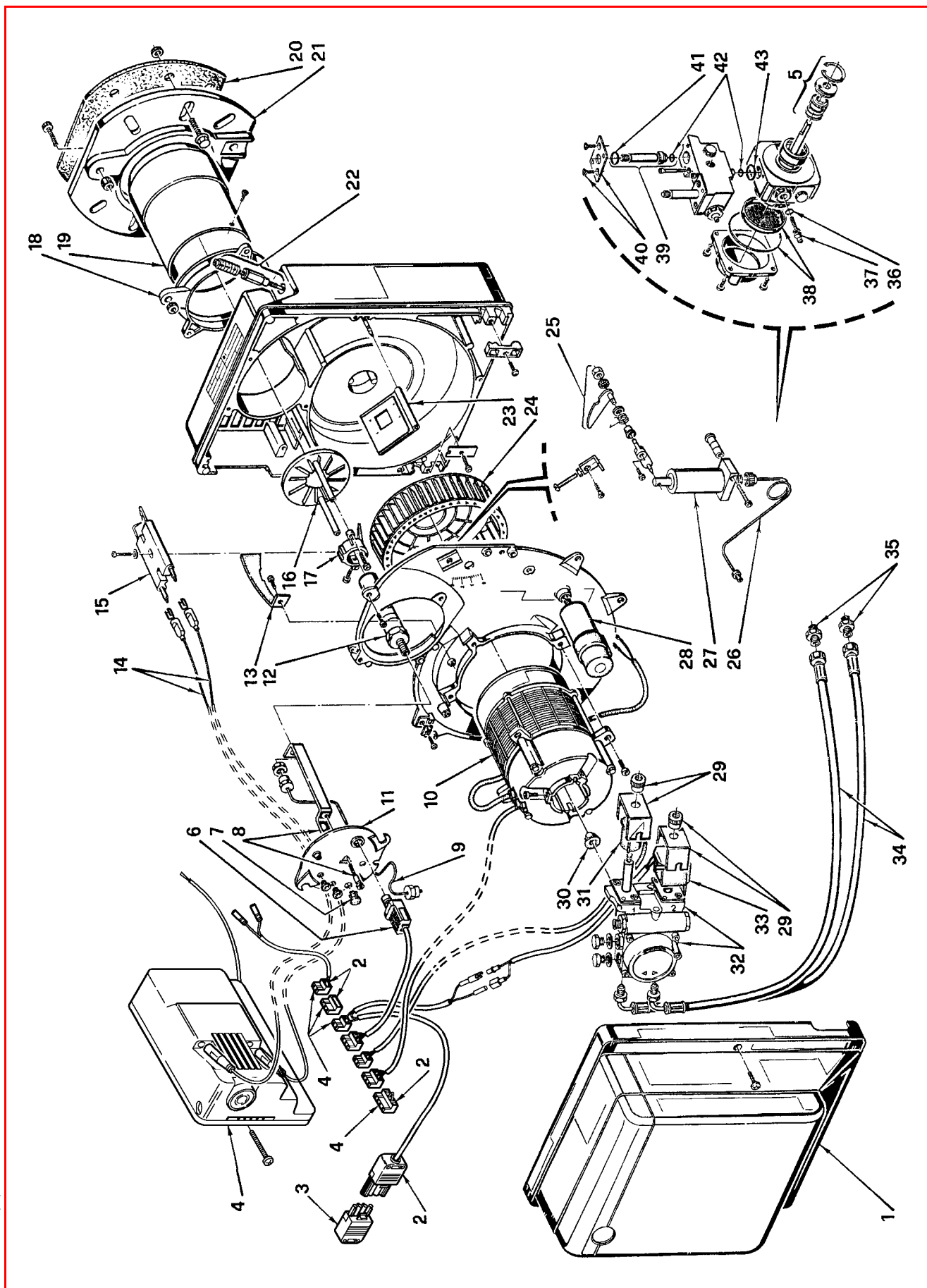

N.	COD.	DESCRIZIONE	DESCRIPTION	DESCRIPTION	BESCHREIBUNG	DENOMINACIÓN	*
1	3007641	COFANO	COVER	CAPOT	VERKLEIDUNG	ENVOLVENTE	
2	3020027	GRUPPO PROTEZIONI	PROTECTION ASSEMBLY	GROUPE PROTECTION	SCHUTZSYSTEM	CONJUNTO PROTECCIÓN	
3	3006957	SPINA A 4 POLI	4 PIN PLUG	FICHE 4 POLES	4 - POLIGER STECKER	CONECTOR MACHO DE 4 CONTAC	
4	3001168	APPARECCHIATURA MO550	CONTROL BOX MO550	BOITE DE CONTROLE MO550	STEUERGERÄT MO550	CAJA DE CONTROL MO550	B
5	3000439	ORGANO DI TENUTA	PUMP SEAL	ORGANE D'ETANCHEITE	WELLENDICHTUNGSEINSATZ	CONJUNTO ESTANQUIDAD	A
6	3007492	FOTORESISTENZA	P.E. CELL	CELLULE PHOTORESIST.	FOTOWIDERSTAND	FOTORESISTENCIA	
7	3007458	VETRINO	VIEWING PORT	REGARD	SCHAUGLAS	MIRILLA	
8	3007644	STAFFA E VITE	BRACKET AND SCREW	SUPPORT ET VIS	TRAGBÜGEL UND SCHRAUBE	SOPORTE ARRASTRE Y TORNILLO	
9	3007866	TUBO	TUBE	TUYAU	DRUCKROHR	TUBO	
10	3008492	MOTORE	MOTOR	MOTEUR	MOTOR	MOTOR	
11	3007642	COPERCHIO	COVER	COUVERCLE	DECKEL	TAPA	
12	3007496	PORTAUGELLO	NOZZLE HOLDER	PORTE-GICLEUR	DÜSENSTOCK	PORTABOQUILLA	C
13	3007651	CONVOGLIATORE	SUCTION DUCT	CONVOYEUR D'AIR	LUFTLEITBLECH	GUÍA	A
14	3002324	COLLEGAMENTO A.T.	HIGH VOLTAGE LEAD	CABLE HAUTE TENSION	KABEL ZÜNDELEKTRODEN	CABLES ELECTRODOS	A
15	3007495	GRUPPO ELETTRODI	ELECTRODE ASSEMBLY	GROUPE ELECTRODES	ELEKTRODENBLOCK	ELECTRODOS	A
16	3007645	ELICA	DIFFUSER DISC	ACCROCHE FLAMME	STAUSCHEIBE	DISCO ESTABILIZADOR	A
17	3007466	SUPPORTO	SUPPORT	PORTE ACCROCHEUR	HALTERUNG	SOPORTE	
18	3007646	COLLARE	COLLAR	COLLIER	BRENNERFLANSCH	COLLARÍN	
19	3007647	BOCCAGLIO	BLAST TUBE	GUEULARD	FLAMMROHR	TUBO LLAMA	B
20	3005813	SCHERMO	GASKET	JOINT ISOLANT	KESSELFLANSCH-DICHTUNG	JUNTA AISLANTE	A
21	3005814	FLANGIA	FLANGE	BRIDE	FLANSCH	BRIDA	
22	3007648	REG. SERRANDA 2° STADIO	2 nd STAGE AIR DAMPER REG.	REG. VOLET AIR 2 ^{ème} ALLURE	2. ST. LUFTKLAPPENREGLER	CONJUNTO REGUL. REG. 2° ETAPA	
23	3007650	SERRANDA	AIR DAMPER	VOLET AIR	LUFTKLAPPE	REGISTRO DEL AIRE	
24	3007652	GIRANTE	FAN	TURBINE	GEBLÄSERAD	TURBINA	C
25	3008567	REG. SERRANDA 1° STADIO	1 st STAGE AIR DAMPER REG.	REG. VOLET AIR 1 ^{ère} ALLURE	1. ST. LUFTKLAPPENREGLER	CONJUNTO REGUL. REG. 1° ETAPA	
26	3007867	TUBO	TUBE	TUYAU	DRUCKROHR	TUBO	
27	3007784	MARTINETTO	HYDRAULIC JACK	VERIN AIR	LUFTKLAPPE DRUCKKOLBEN	HIDRÁULICO DE AIRE	
28	3007655	CONDENSATORE 6,3 µF	CAPACITOR 6.3 µF	CONDENSATEUR 6,3 µF	KONDENSATOR 6,3 µF	CONDENSADOR 6,3 µF	B
29	3006553	MANTELLO E POMELLO	SHELL AND KNOB	ETRIER ET ECROU	BÜGEL UND KNOPF	PROTECCIÓN BOBINA	
30	3000443	GIUNTO	JOINT	ACCOUPLMENT	PUMPENKUPPLUNG	ACOPLAMIENTO	A
31	3007481	BOBINA 1	COIL 1	BOBINE 1	MV SPULE 1	BOBINA 1	B
32	3007854	GRUPPO POMPA-VARIATORE	SPEED GEAR PUMP	POMPE VARIATEUR	GETRIEBE-PUMPE	CONJUNTO BOMBA-VARIADOR	
33	3008916	BOBINA 2	COIL 2	BOBINE 2	MV SPULE 2	BOBINA 2	B
34	3005720	TUBO FLESSIBILE	FLEXIBLE OIL LINE	FLEXIBLE	SCHLAUCH	TUBO FLEXIBLE	
35	3009068	RACCORDO	CONNECTOR	MAMELON	NIPPEL	RACORD	C
36	3007028	ANELLO OR	O - RING	JOINT TORIQUE	O - RING	JUNTA TÓRICA	C
37	3007202	REGOLATORE	REGULATOR	REGULATEUR	REGLER	REGULADOR	
38	3008653	FILTRO - ANELLO OR	FILTER - O - RING	FILTRE - JOINT TORIQUE	FILTEREINSATZ - O - RING-DICHTUNG	FILTRO - JUNTA TÓRICA	C
39	3006925	VALVOLA	NEEDLE VALVE	VANNE	NADELVENTIL	VÁLVULA	B
40	3007203	PIASTRINA	PLATE	PLAQUETTE ETRIER	PLATTE	PLATINA	
41	3007029	ANELLO OR	O - RING	JOINT TORIQUE	O - RING	JUNTA TÓRICA	C
42	3007156	ANELLO OR	O - RING	JOINT TORIQUE	O - RING	JUNTA TÓRICA	C
43	3007167	ANELLO OR	O - RING	JOINT TORIQUE	O - RING	JUNTA TÓRICA	C

*

RICAMBI CONSIGLIATI - ADVISED SPARE PARTS - RECHARGE CONSEIL - EMPFOHLENE ERSATZTEILE - RECAMBIOS ACONSEJADOS

A = Ricambi per dotazione minima - Spare parts for minimum fittings - Pièces détachées pour équipement minimum - Ersatzteile für minimale Ausstattung - Recambios para equipamiento mínimo.

A+B = Ricambi per dotazione base di sicurezza - Spare parts for basic safety fittings - Pièces détachées pour équipement standard de sécurité - Ersatzteile für Sicherheitsgrundausrüstung - Recambios para equipamiento básico de seguridad.

A+B+C = Ricambi per dotazione estesa di sicurezza - Spare parts for extended safety fittings - Pièces détachées pour équipement complet de sécurité - Ersatzteile für erweiterte Sicherheitsausstattung - Recambios para equipamiento general de seguridad.



RIELLO S.p.A.

I-37048 San Pietro di Legnago (VR)

Tel.: +39.0442.630111

[http:// www.rielloburners.com](http://www.rielloburners.com)
